



Si option « serrure en applique » (1/5)

Composant nécessaire



Gabarit de perçage papier
Qté 1



Ruban
adhésif



Scie cloche
Ø20mm



Forêt Ø3mm



Forêt Ø3,5mm

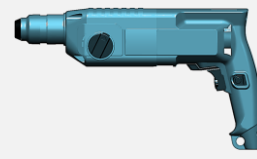

Perceuse

Pose de la serrure en applique

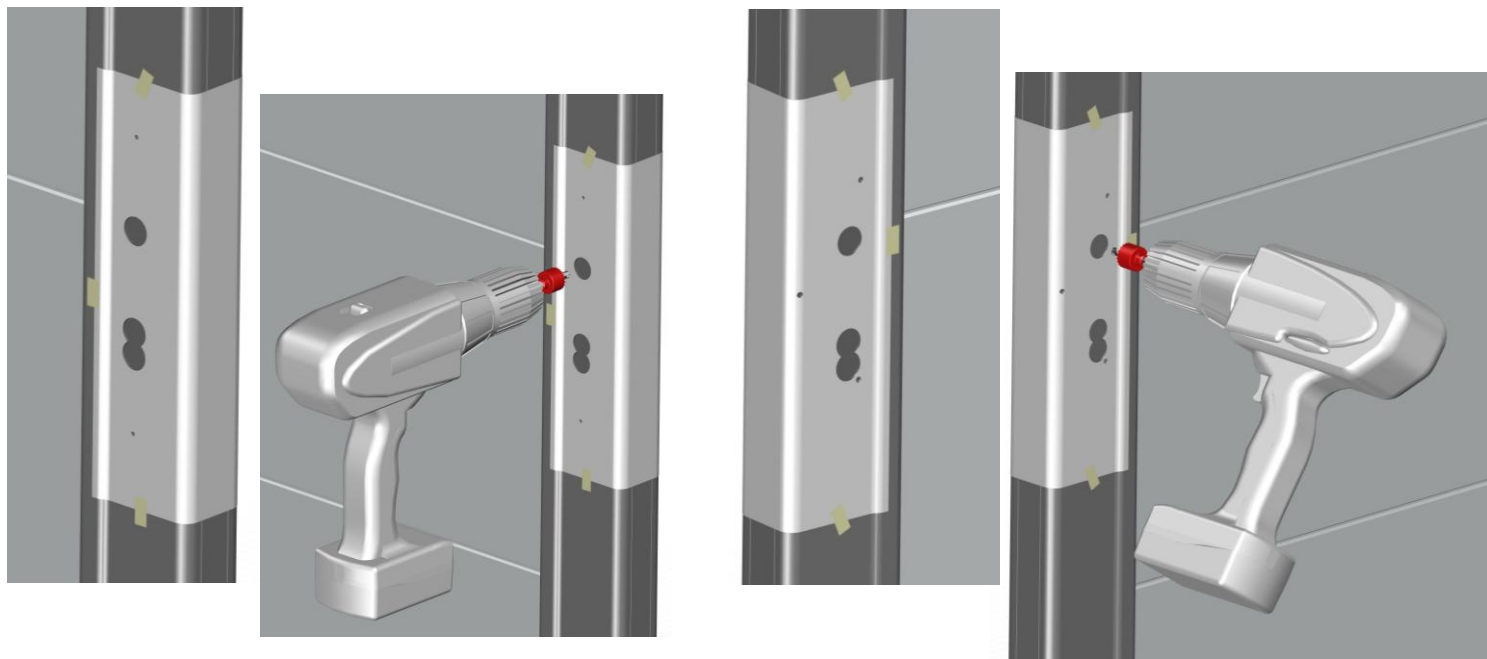

Mettez en place le gabarit de perçage en suivant les instructions situées dessus. Effectuez les perçages Ø20mm côté propriété et côté rue à l'aide d'un scie cloche

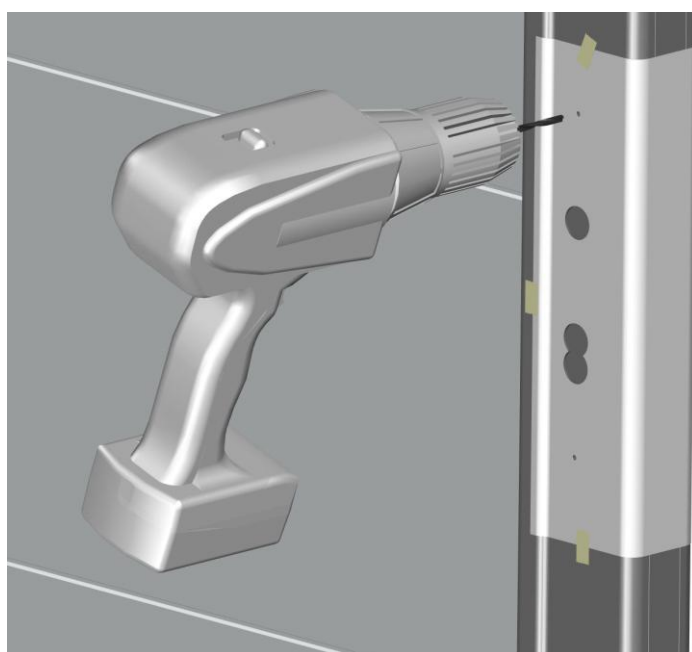

Effectuez ensuite les 2 perçages côté rue à l'aide d'un foret Ø3mm



Terminez par les 3 perçages côté propriété à l'aide d'un foret Ø3,5mm



Si option « serrure en applique » (2/5)

Composants nécessaires

Outil nécessaire

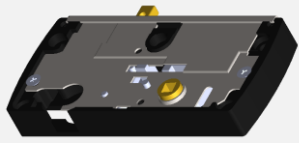

Bloc serrure
Qté 1



Enjoliveur de
serrure Qté 1



Vis tête bombée
inox 4,8x38 Qté 3



Vis tête fraisée
inox 3,5x16 Qté 1



Tournevis
cruciforme

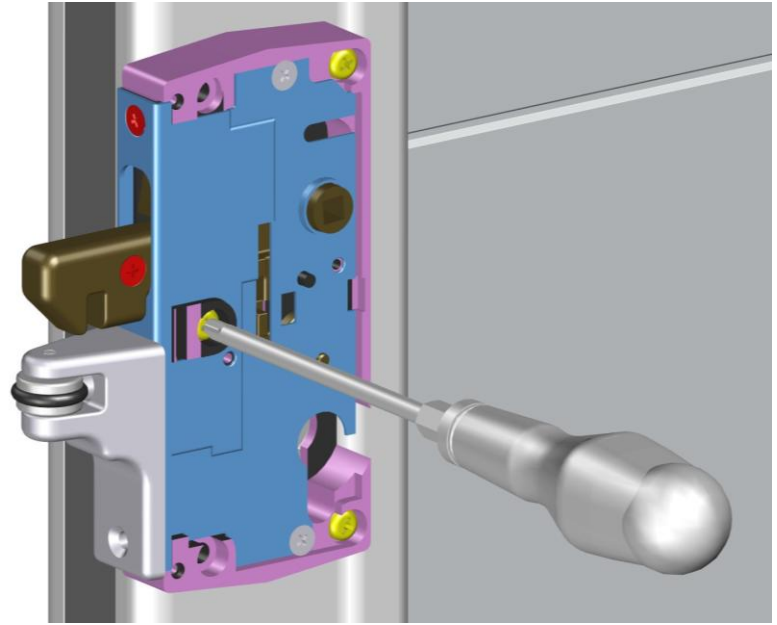
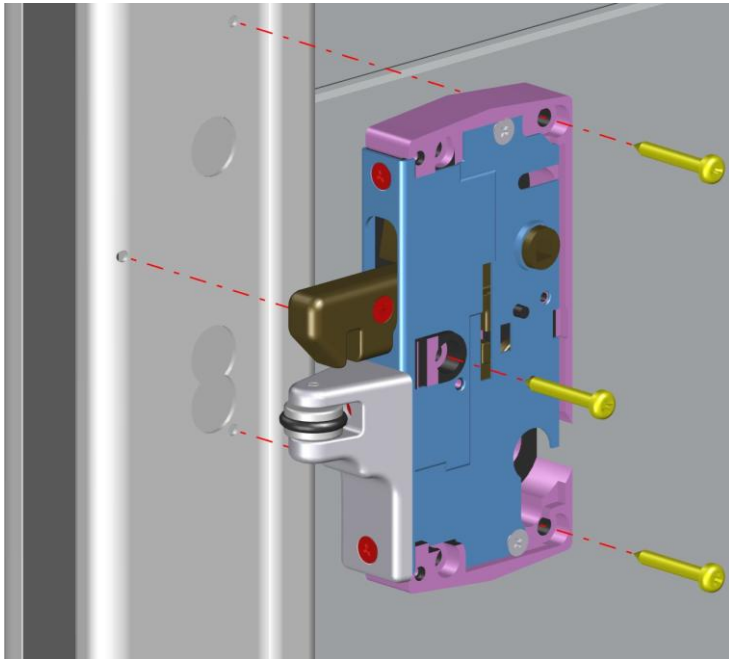

Mettez en place et effectuez le serrage des 3 vis tête bombée 4,8x38

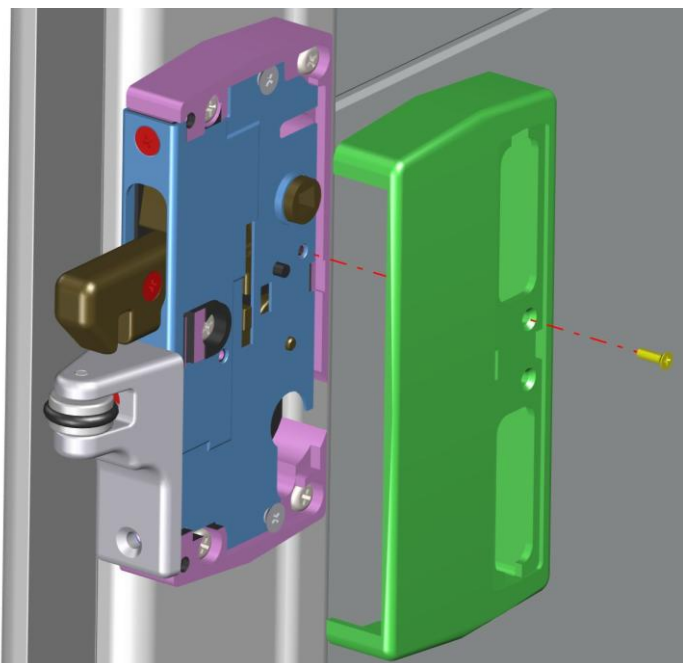

Positionnez l'enjoliveur de serrure
et sa vis 3,5x16 de maintien

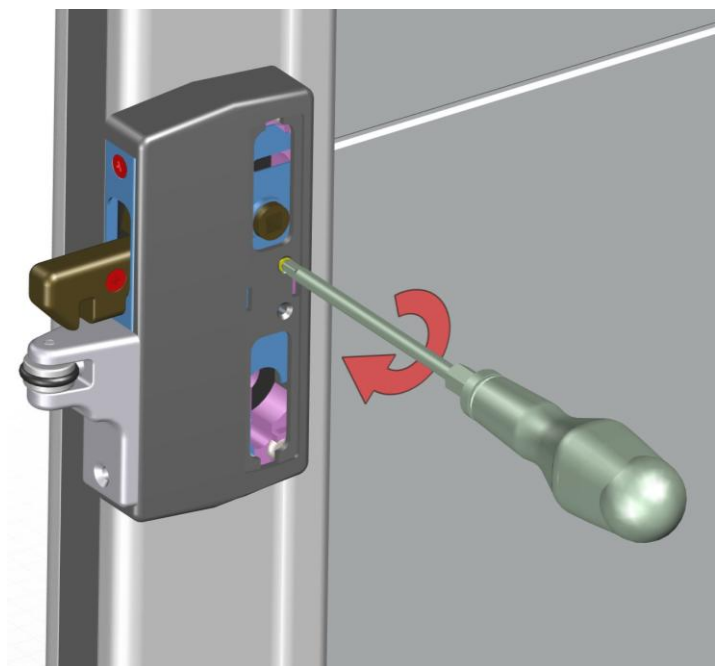

Effectuez le serrage de la vis de maintien
à l'aide d'un tournevis cruciforme



Si option « serrure en applique » (3/5)

Composants nécessaires

Outil nécessaire



Enjoliveur de cylindre à clipper Qté 1

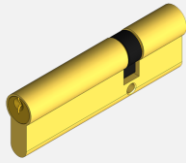

Cylindre Qté 1



Vis inox tête fraisée M5x70 Qté 1



Tournevis cruciforme



Clippez le cache cylindre

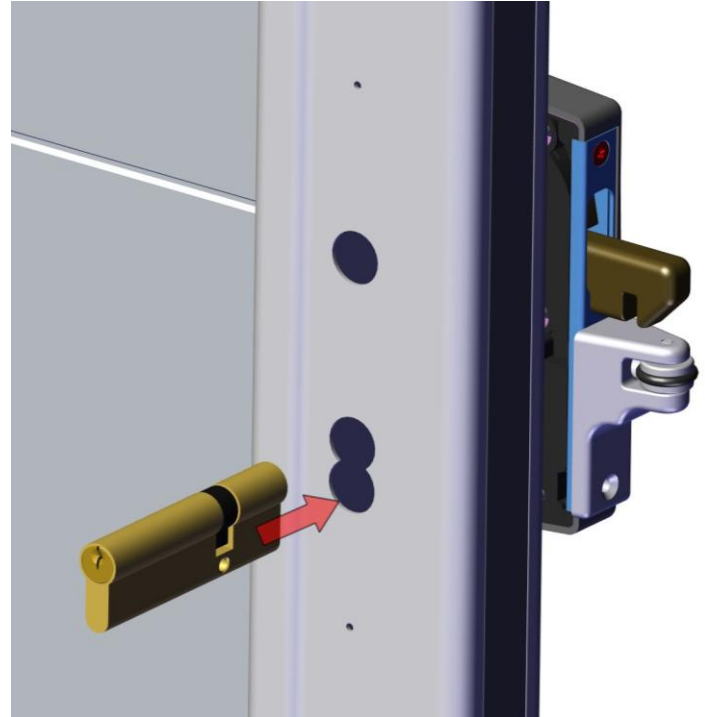

Mettez en place le cylindre



Effectuez le serrage du cylindre à l'aide de la vis inox tête fraisée M5x70





Si option « serrure en applique » (4/5)

Composants nécessaires



Carré inox
Qté 1

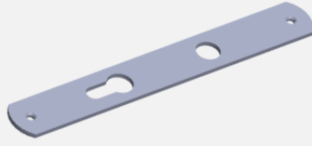

Plaque de propreté
extérieure Qté 1



Béquille extérieure
Qté 1

Outils nécessaires

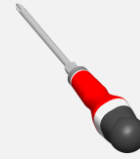

Tournevis
cruiforme



Clé alène de 3

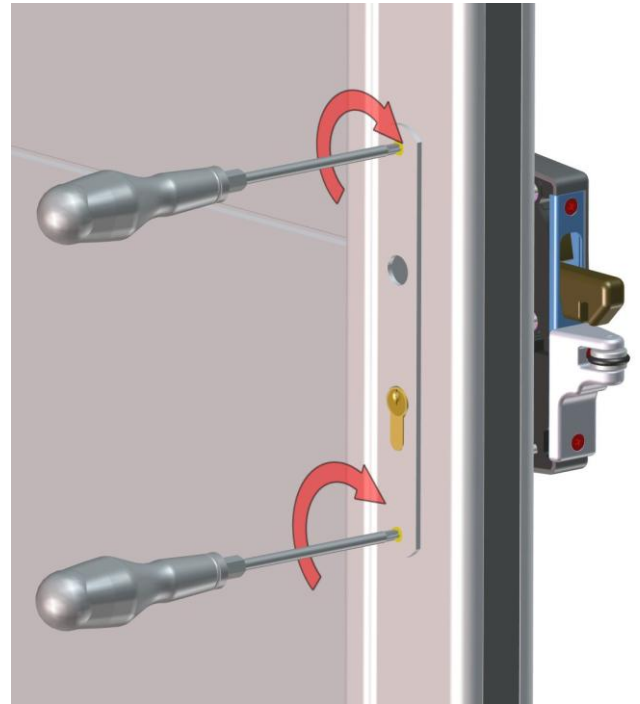
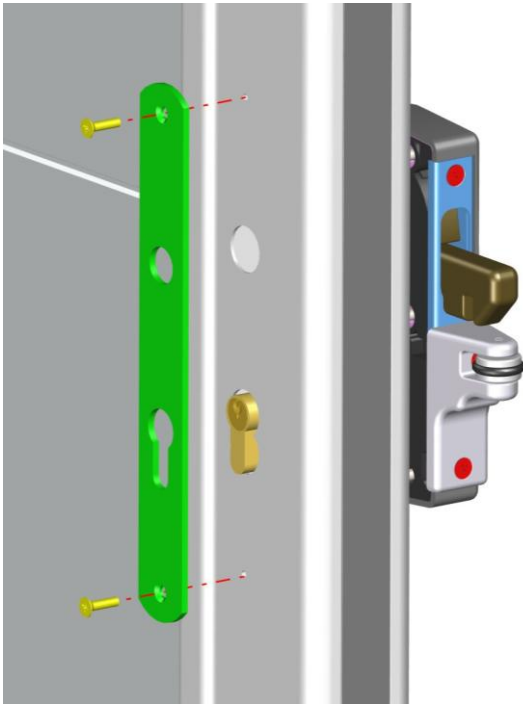

Mettez en place la plaque de propreté (côté rue) puis effectuez le vissage à l'aide des 2 vis inox tête fraisée

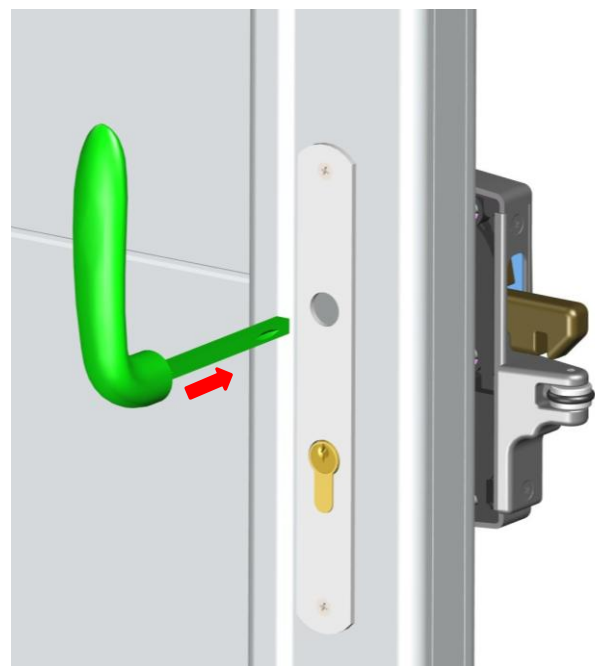
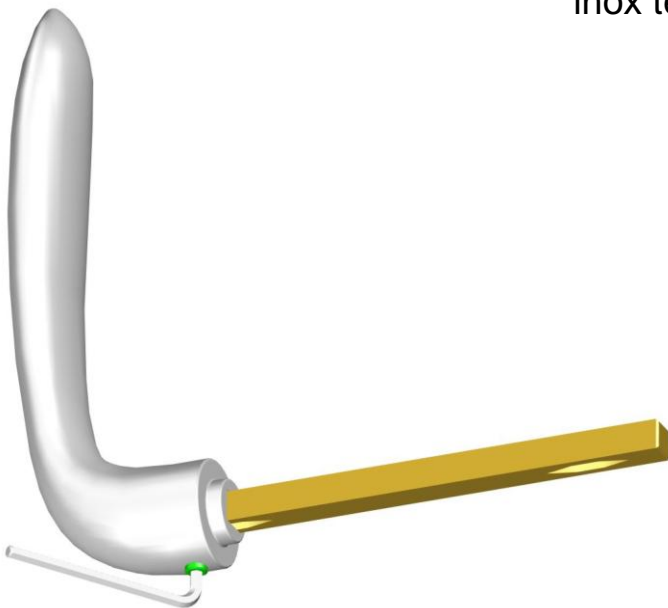

A l'aide de la clé alène, effectuez le vissage de la béquille sur le carré inox puis insérez l'ensemble dans le montant et le bloc serrure



Si option « serrure en applique » (5/5)

Composant nécessaire



Béquille intérieure
Qté 1

Outil nécessaire

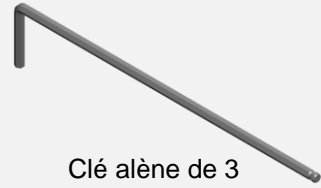

Clé alène de 3

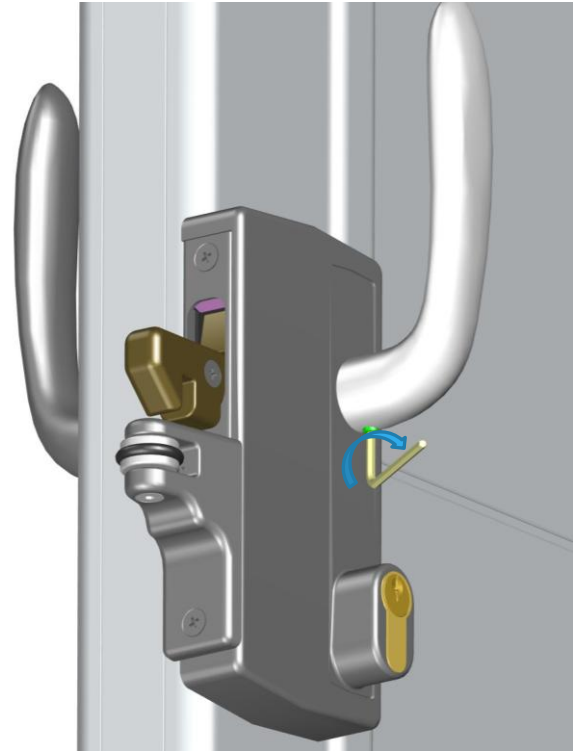
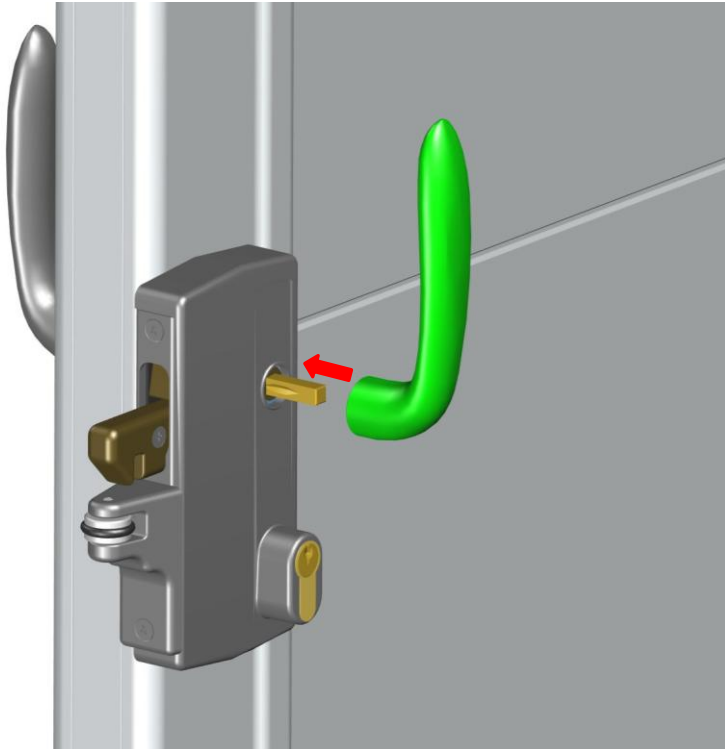

Insérez la béquille intérieure sur le carré puis effectuez le serrage à l'aide de la clé alène

